

Black Box Theater

CONTROL ROOM

CONTROL ROOM. The audio rack in the Control Room houses audio I/O for the console, plus an MH10 to tie in the RJ45 A-Net jacks in the performance space.

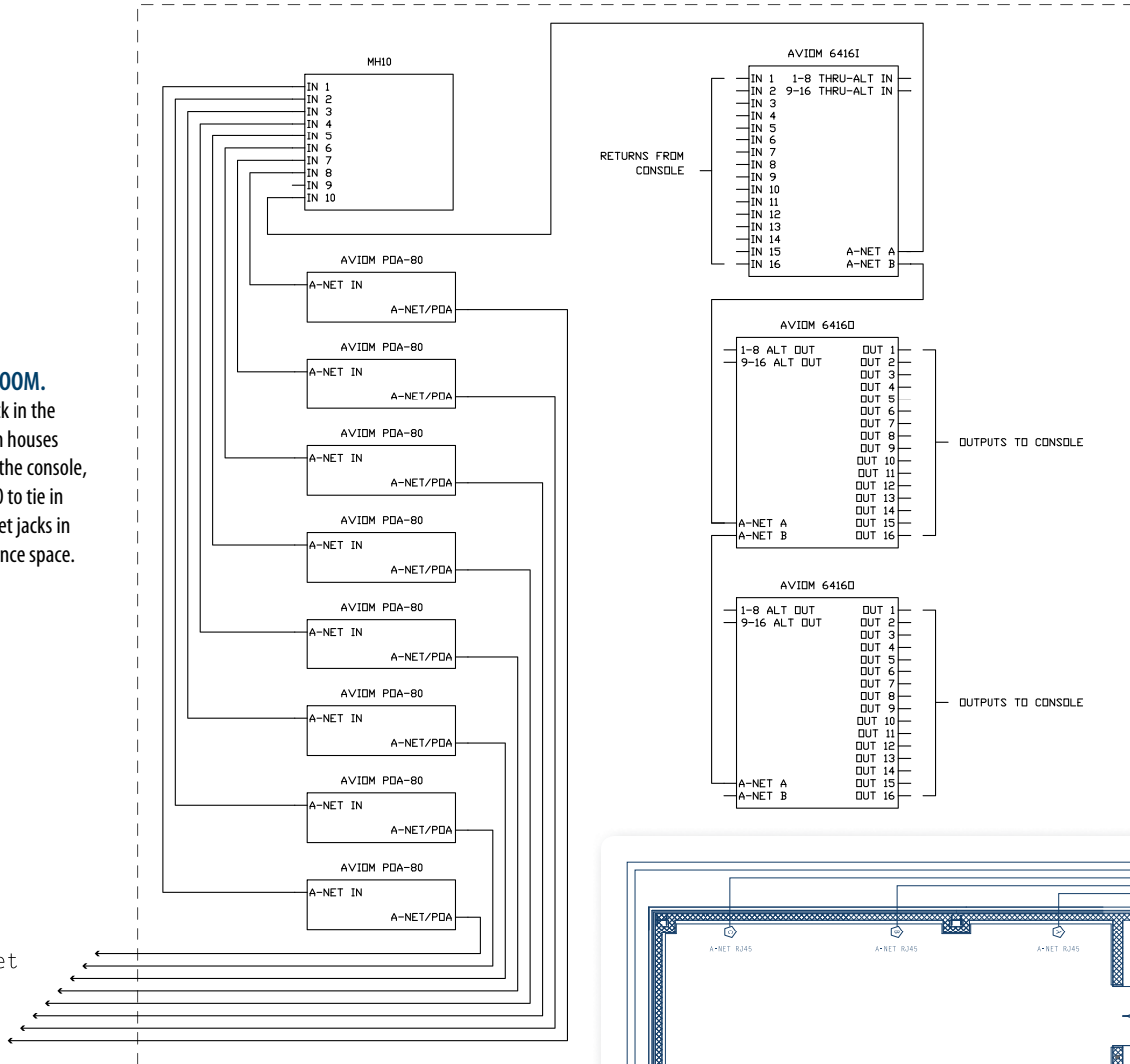

to A-Net jacks

STAGE DROP BOX

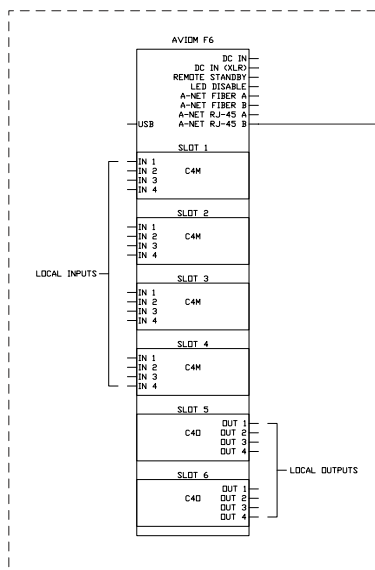

to any A-Net jack

STAGE DROP BOX. With an Aviom F6 encased in an SK6 Stage Kit, the stage drop box is outfitted to provide 16 mic/line inputs and 8 analog outputs. It can be connected to any RJ45 A-Net jack in the performance space.

