

Mid-Sized Theater/School Auditorium

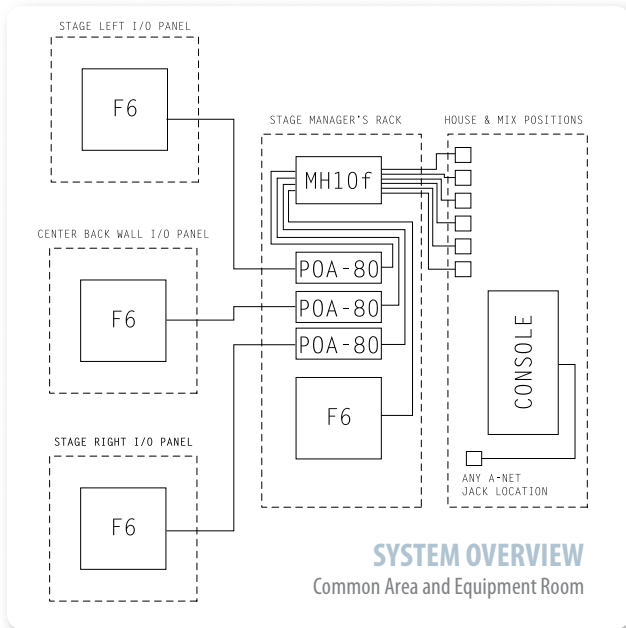

STAGE I/O PANEL (typical 1 of 3). Each I/O panel on stage is outfitted to support up to 12 mic/line inputs and four analog outputs. I/O panels may be located at stage right, stage left, and the back wall.

STAGE MANAGER'S RACK. The Stage Manager's rack provides I/O to and from floor pockets, overhead mics, and the catwalk. It also contains the power supplies for the AllFrames throughout the system and the MH10 for merging all cable runs.

HOUSE & MIX LOCATIONS. RJ45 jacks tied back to the MH10 allow the mix console to be located nearly anywhere and connected into the Aviom Pro64® network.

